



# Drill 1



**Grammar:** Simple future tense: *will* and *will not*

**Usage:** Completing a dialogue

Date:

Time allowed: 15 minutes

## Grammar

**A** Harry will go to a country park on Sunday. He is now thinking about what he will and will not do. Complete the sentences with the correct forms of the words in the brackets. Suggested time: 3 minutes

e.g. I will take (take) an umbrella with me.

1. I \_\_\_\_\_ (keep) the place clean.

2. I \_\_\_\_\_ (bring) enough food.

3. I \_\_\_\_\_ (play) the music loud.

4. I \_\_\_\_\_ (pick) the flowers.



**B** Harry is writing a letter to Helen about the visit to the country park. Complete the letter with the correct forms of the words in the box.

Suggested time: 4 minutes

take go walk have be do

Hi Helen,

I e.g. will go to Lion Rock Country Park with Dad and Mum on Sunday! I believe it (1) \_\_\_\_\_ fun to go there.

We (2) \_\_\_\_\_ a bus to the country park. The country park is very big. First we (3) \_\_\_\_\_ around the park to see the trees and monkeys. But we (4) \_\_\_\_\_ to see the Amah Rock because Mum thinks it is too dangerous to climb up the hill. We (5) \_\_\_\_\_ barbecue in the afternoon.

What (6) \_\_\_\_\_ you \_\_\_\_\_ on Sunday? Do you want to join us?

Harry



**B4** Look at the reason (i.e. 'because Mum thinks ...') and see whether you should use 'will' or 'will not' in your answer.

## Usage

**C** Harry is talking to Peter, his friend from Singapore. Peter will come to Hong Kong for holiday. Look at Peter's holiday plan and complete the dialogue.

 Suggested time: 8 minutes

Peter's holiday plan in Hong Kong					
Monday	Tuesday	Wednesday	Thursday	Friday	Saturday
Go to Wong Tai Sin Temple with parents	Watch a film in Mong Kok		Go shopping in Tsim Sha Tsui	Eat seafood on Cheung Chau	Go to Hong Kong Disneyland with cousins

e.g. Harry: Will you eat seafood?

Peter: Yes, I will. I will eat seafood on Cheung Chau on Friday.

1. Harry: Will you go shopping?

Peter: Yes, \_\_\_\_\_ . I will \_\_\_\_\_ .

2. Harry: Will you watch a concert?

Peter: No, \_\_\_\_\_ . But I \_\_\_\_\_  
on Tuesday.

3. Harry: \_\_\_\_\_

Peter: Yes, I will. I will go to Wong Tai Sin Temple with my parents on Monday.

4. Harry: Will you go to Ocean Park?

Peter: \_\_\_\_\_ , \_\_\_\_\_ . But I \_\_\_\_\_  
\_\_\_\_\_ on the last day.

5. Harry: Will you have time to go to the Wetland Park for a whole day?

Peter: \_\_\_\_\_ , \_\_\_\_\_ . I \_\_\_\_\_  
\_\_\_\_\_ .



**Smart Tip** C3 When you form a question, start the question with the word 'will' and end it with a question mark.



**Focus**

**Reading:** A travel brochure  
**Vocabulary:** Touring activities

Date: \_\_\_\_\_

Time allowed: 15 minutes

# Reading

Jenny will join the holiday tour in the travel brochure below. Read the brochure carefully.

## Sunshine Travel

Special Price: \$3,888

### *Have a wonderful holiday in Tokyo!*

**Day 1:** We will arrive at Tokyo International Airport at noon. In the afternoon, we will go shopping in Shinjuku. The place has a lot of shops selling the newest fashion. At night, we will have a mouth-watering seafood dinner.

**Day 2:** After breakfast, we will go to Tokyo Disneyland for a day of fun. Try the breathtaking rides and watch a 4-D movie there! Entrance fee and a lunch coupon are included. At night, we will go up the Tokyo Tower to have a 360-degree view of Tokyo.

**Day 3:** We will look at the old Tokyo. In the morning, we will go to the Edo-Tokyo Museum to learn about the history of Tokyo. We will then have a sushi lunch before visiting the temples. There will be another shopping time in the evening.



**Day 4:** We will go to the zoo in Ueno. You can see different animals moving around outdoors. We will catch the flight back to Hong Kong at night.

**A** Answer the following questions in complete sentences.

Suggested time: 6 minutes

1. On which days will Jenny go shopping?  
\_\_\_\_\_
2. What can Jenny buy in Shinjuku?  
\_\_\_\_\_
3. Which amusement park will Jenny go to?  
\_\_\_\_\_

**Smart Tip** **A1** Pay attention to the keyword 'days' in the question. There is more than one day when we have an '-s' in 'days'.

4. Will Jenny need to pay to go to the amusement park?

\_\_\_\_\_

5. Where can Jenny learn about the past of Tokyo?

\_\_\_\_\_

6. The tour will start on Saturday. When will Jenny be back in Hong Kong?

\_\_\_\_\_

**B** Look at the pictures below. On which day will Jenny do these activities?

Write the correct numbers in the blanks.  Suggested time: 4 minutes



1. Day \_\_\_\_



2. Day \_\_\_\_



3. Day \_\_\_\_



4. Day \_\_\_\_

## Vocabulary

**C** Jenny is telling Kelvin what she will do in Tokyo. Complete the sentences with the words in the box.  Suggested time: 5 minutes

clothes    zoo    view    museum    rides

1. I will buy \_\_\_\_\_. I want to get a new jacket and a T-shirt.

2. I will go on several \_\_\_\_\_ at Tokyo Disneyland. It will be an exciting experience.

3. I will visit a \_\_\_\_\_ to know more about the old Tokyo.

4. I will see the \_\_\_\_\_ from the Tokyo Tower at night and take some photos there.

5. I will visit a \_\_\_\_\_ on the last day. I expect to see the pandas there.



**A6** Find out how many days Jenny will stay in Japan first.



# Drill 3



**Grammar:** • Prepositions of direction  
• Imperatives

**Usage:** Giving instructions

Date: \_\_\_\_\_

Time allowed: 15 minutes

## Grammar

**A** Alice is talking about the places around the MTR station. Fill in the blanks with the words on the right. Suggested time: 3 minutes

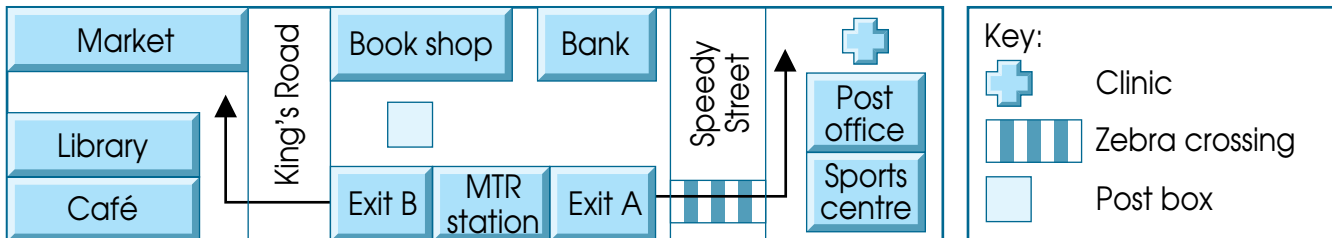

- Key:
- Clinic
  - Zebra crossing
  - Post box

- The sports centre is \_\_\_\_\_ the post office.
- The library is \_\_\_\_\_ the market.
- The clinic is \_\_\_\_\_ Speedy Street.
- The post box is \_\_\_\_\_ the bookshop.

at the end of  
opposite  
in front of  
next to

**B** Alice is writing notes about how to go to the clinic and the market. Read the map above and complete her notes with the words on the right.

Suggested time: 4 minutes

**How to go to the clinic:** (1) \_\_\_\_\_ the MTR station Exit A. (2) \_\_\_\_\_ the zebra crossing. (3) \_\_\_\_\_ into Speedy Street. The clinic is next to the post office.

**How to go to the market from Exit B:** (4) \_\_\_\_\_ to the café. (5) \_\_\_\_\_. (6) \_\_\_\_\_. The market is at the end of the street.

Cross the road  
Go out of  
Turn left  
Turn right  
Walk across  
Walk straight on



**B3 & 5** Make sure you do not mix up left and right.

## Usage

**C** Alice meets some tourists in the street. They ask her for directions. Complete their dialogues with the words in the brackets. Use the words and the map below to help you.  Suggested time: 8 minutes

walk across	walk along	walk straight on
is opposite	is next to	is at the end of
Excuse me. How can I get to	turn left	turn right

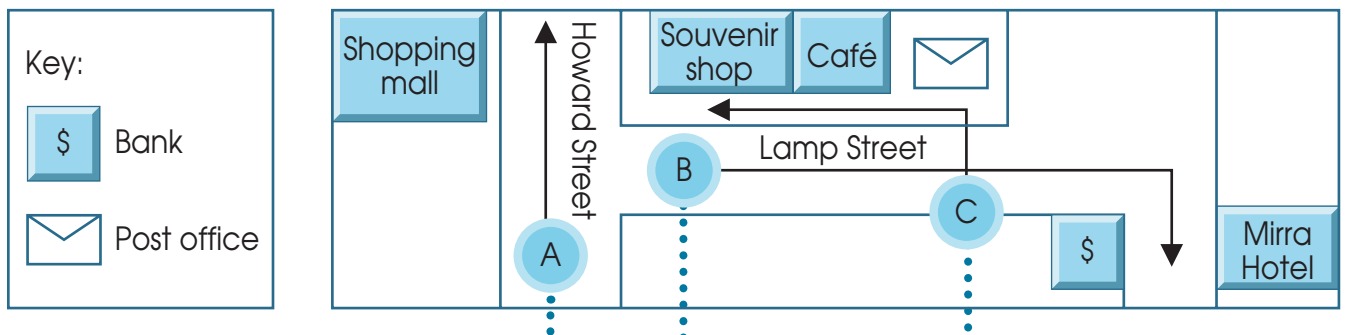

e.g. **Tourist A:** Excuse me. How can I get to the shopping mall?  
(the shopping mall)

**Alice:** Walk along Howard Street. The shopping mall is at the end of the street. (The shopping mall the street)

**Tourist B:** Excuse me. How can I get to the Mirra Hotel?

**Alice:** (1) \_\_\_\_\_  
Lamp Street. (2) \_\_\_\_\_  
(3) \_\_\_\_\_  
\_\_\_\_\_ (Mirra Hotel the bank)

**Tourist C:** (4) \_\_\_\_\_  
\_\_\_\_\_  
\_\_\_\_\_  
(the souvenir shop)

**Alice:** (5) \_\_\_\_\_  
\_\_\_\_\_ Lamp Street.  
(6) \_\_\_\_\_  
and then (7) \_\_\_\_\_  
\_\_\_\_\_ the street.  
(8) \_\_\_\_\_  
\_\_\_\_\_  
\_\_\_\_\_  
(The souvenir shop the café)

 **Smart Tip** **C** Look at the arrows for the directions.



# Drill 4

**Focus**  
**Reading:** A website  
**Vocabulary:** Facilities

Date: \_\_\_\_\_

Time allowed: 15 minutes

## Reading

Alan is looking at the website of Hope Youth Centre. Read the website carefully.

http://www.hopeyouthcentre.hk/Q&A

**Questions about Hope Youth Centre:**

- How can I become a member of the centre?**  
Bring a photo and go to the information counter to apply for a membership card. The fee is 10 dollars.
- What are the opening hours?**  
We are open from 10 a.m. to 10 p.m. every day but closed on Wednesdays.
- What facilities can members enjoy?**  
Members can borrow books and magazines from our library. They can also use our ping-pong tables. Our multipurpose room has board games and chess for them to play with their friends.
- Can members use the computers in the centre?**  
Yes. There are six computers for members to use in the centre. They can surf the Internet and listen to music on the computer but they need to bring their own earphones.
- What other services can members enjoy?**  
Members can take our courses here at a discount, such as the cookery and swimming classes. You can get more information at the information counter.
- How long is the membership?**  
It lasts for one year. Remember to bring a recent photo and the fee with you when you renew your membership.

**A** Alan's sister, Sarah, is asking him questions about Hope Youth Centre. Answer the following questions in complete sentences.

Suggested time: 6 minutes

- Sarah: How many days is Hope Youth Centre open in a week?  
Alan: \_\_\_\_\_
- Sarah: How much is the membership fee?  
Alan: \_\_\_\_\_



**A1** Think about how many days there are in a week and how many days the youth centre is closed.



3. Sarah: What should I do if I want to listen to music on the computer in the youth centre?

Alan: \_\_\_\_\_

4. Sarah: How can I know more about the classes?

Alan: \_\_\_\_\_

**B** Alan is telling Sarah more about Hope Youth Centre. Decide whether the sentences are true (T) or false (F).  Suggested time: 4 minutes

e.g.	T	You can borrow books at Hope Youth Centre.
1.		You have to renew your membership every year.
2.		You can join the interest classes for free.
3.		You cannot play games in the multipurpose room there.
4.		You can enjoy the sports facilities there.

## Vocabulary

**C** Alan is telling Sarah about the facilities near their home. Fill in the blanks with the words in the box.  Suggested time: 5 minutes

bakery    bank    clinic    market    post office

1. We can buy stamps for Grandma's letter at the \_\_\_\_\_.
2. Mum often takes us to Dr Chan's \_\_\_\_\_ when we feel sick.
3. Mum goes to buy meat and vegetables at the \_\_\_\_\_ every day.
4. Every morning, I buy bread for my breakfast at the \_\_\_\_\_.
5. You can put your red packet money into your savings account at the \_\_\_\_\_.



**C** Read the words in the box and think about what you can do or get in these places first.





# Drill 5



**Grammar:** • Simple past tense  
• *So, because*

**Usage:** Completing an email

Date:

Time allowed: 15 minutes

## Grammar

**A** Kelvin is writing in his diary about what he did at school today. Complete his entry with the correct forms of the words in the brackets.

Suggested time: 3 minutes

3 March Monday

Cloudy

Today, my class (1) \_\_\_\_\_ (have) a football match with Class 4B. John (2) \_\_\_\_\_ (train) and (3) \_\_\_\_\_ (lead) the team very well. Our team (4) \_\_\_\_\_ (score) two goals in the first half of the game. Miss Wong (5) \_\_\_\_\_ (come) to see the match too. We all (6) \_\_\_\_\_ (cheer) for them loudly. At last, our team (7) \_\_\_\_\_ (beat) Class 4B. We (8) \_\_\_\_\_ (be) all very excited.

**B** Kelvin is telling his mother about the football match today. Fill in the blanks with 'so' or 'because'. Suggested time: 4 minutes

e.g. There was a football match between my class and Class 4B  
\_\_\_\_\_ **so** \_\_\_\_\_ I went to cheer for my classmates.

- Sam did not join the match \_\_\_\_\_ he was absent from school.
- Alice had the piano lesson today \_\_\_\_\_ she left early.
- John played very well in the match \_\_\_\_\_ the school awarded him 'The Best Player of the Match'.
- Miss Wong bought us sweets \_\_\_\_\_ our class won the match.



**A** Some verbs do not change in the past tense, e.g. 'cut', 'hurt'.

## Usage

**C** Kelvin is writing an email to Harry about his unforgettable day. Complete the email using the sentences in the box. Remember to change the words in the brackets to the correct forms.  Suggested time: 8 minutes



because I (see) a road accident	so they (get) off
so he (change) its direction	because he (save) her dog
because there (be) no pedestrian on the pavement	so I (walk) to the post office near my school

To:

Subject:

Hi Harry,

Yesterday was very unforgettable to me e.g. because I saw a road accident.

I wanted to buy some stamps (1) \_\_\_\_\_.

On my way, a dog suddenly ran onto the road. The driver of a minibus saw it (2) \_\_\_\_\_.

It crashed into a post box. Luckily, the minibus did not hurt anyone (3) \_\_\_\_\_.

The passengers on the minibus were scared. They wanted to know what happened (4) \_\_\_\_\_.

The dog's owner thanked the driver (5) \_\_\_\_\_.

Write to me about your unforgettable day.

Kelvin



**C** Read through the email to have a general idea of the story before choosing from the sentences.



# Integrated Test 1

Date:

Time allowed: 35 minutes



- Revision on Drills 1 to 5
- Writing a blog entry

## Reading (22 marks)

Helen wrote an email to Janet about her bad day. Read her email carefully.

To: janet77@happymail.com

Subject: A bad day!

Hi Janet,

How are you? Yesterday was a 'Black Friday' to me. Let me tell you what happened.

Yesterday, I borrowed a lot of books from the library. I put them into a carrying bag and walked a long way to the Kung Tong station to take the MTR home. Luckily, there were very few people on the train so I found a seat easily.

I put the bag under the seat and started to talk with Kitty on the phone. We talked about our class picnic which will be in Sai Kung next Saturday. Suddenly, I found that my train already reached Mongkok station. I needed to change to a bus near this station! I rushed to the door and got off the train.

When I got out of the station, I felt something was not right — I forgot the bag of books! I ran to the service counter to ask the station assistant for help. He asked me to leave my telephone number and told me to wait for their news. I left the station and took the bus home. I pulled a long face on the way home.

I am still waiting for the news of the books. Next time, when I am on the train, I will not talk on the phone or put my belongings on the floor, no matter how heavy they are!

Helen

**A** Answer the following questions. Suggested time: 10 minutes

1. What day was it when Helen wrote this email? (2 marks)
  - A. Wednesday
  - B. Thursday
  - C. Friday
  - D. Saturday

2. What did Helen do the day before she wrote this email? (2 marks)

- A. She went to the market.
- B. She went to the library.
- C. She bought a bag.
- D. She bought a lot of books.

3. Where did Helen find that she forgot her books? (2 marks)



A.

B.

C.

D.

4. How did Helen go back home? (2 marks)

- A. by bus only
- B. by MTR only
- C. by bus and then by MTR
- D. by MTR and then by bus

5. Where did Helen leave her books on the MTR train? (2 marks)

---

6. What will Helen do next Saturday? (2 marks)

---

7. What did Helen do when she found that she left her books on the train?  
(2 marks)

---

8. What will the staff at the service counter do when they find the books?  
(2 marks)

---

9. How did Helen feel on the way home? (2 marks)

---

10. Which of the following are true? Tick (✓) only TWO boxes. (4 marks)

a.	<input type="checkbox"/>	Helen is waiting for the station assistant to call her.
b.	<input type="checkbox"/>	Helen will not travel by MTR any more.
c.	<input type="checkbox"/>	Helen wrote email to Janet because she wanted to share her bad day with her.

## Vocabulary (14 marks)

**B** Alan is solving a crossword puzzle in the MTR. Help him complete it below.

 Suggested time: 2 minutes

Do you know where they are?

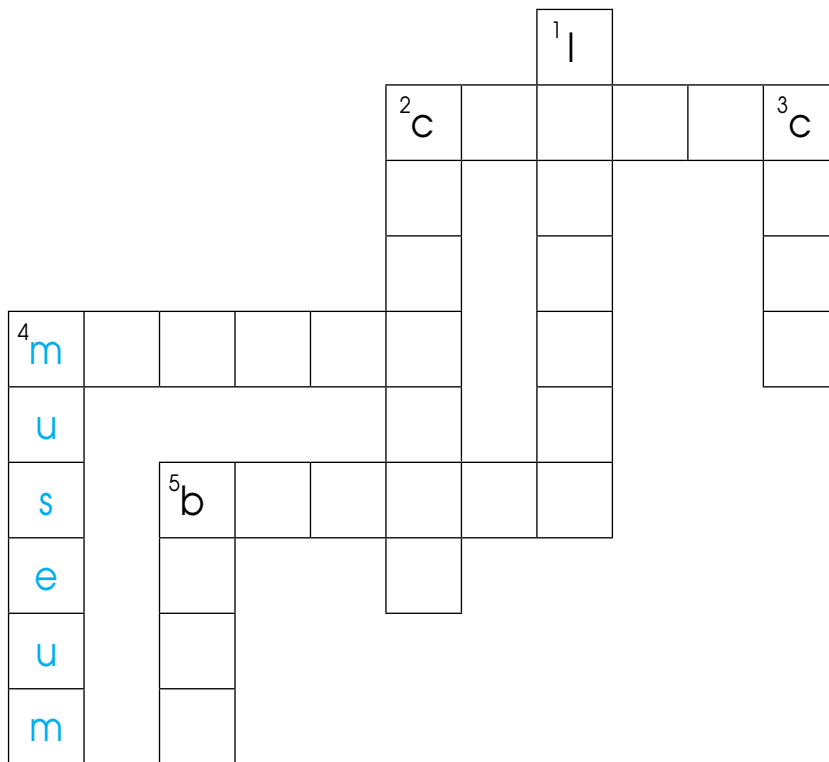

Across	Down
2. You go there when you are sick.	1. You can borrow books there.
4. You can buy vegetables and meat there.	2. You can buy _____ in boutiques.
5. You can buy bread and cakes there.	3. You can have lunch there.
	<b>e.g. 4. You can learn about space in this _____.</b>
	5. You can save money there.

## Grammar and Usage (44 marks)

**C** Harry will visit the Hong Kong Space Museum tomorrow. He is telling his mother what he will do. Look at the timetable and fill in the blanks below. (10 marks)  Suggested time: 3 minutes

Timetable of the visit to the Hong Kong Space Museum	
9:45 a.m.	Meet at the Space Museum
10:00 a.m.	Listen to a talk about space
11:00 a.m.	Have a tour around the museum
12:30 p.m.	Leave the museum

We e.g. will meet (meet) at the Space Museum at 9:45 a.m. tomorrow. We (1) \_\_\_\_\_ (listen) to a talk about space, but we (2) \_\_\_\_\_ (watch) the show there. We (3) \_\_\_\_\_ (have) a tour around the museum after that. We (4) \_\_\_\_\_ (have) lunch after the visit. We (5) \_\_\_\_\_ (leave) at 12:30 p.m.

**D** Harry's mother is teaching Harry how to get to the Space Museum. Fill in the blanks with the words in the box. (10 marks)  Suggested time: 3 minutes

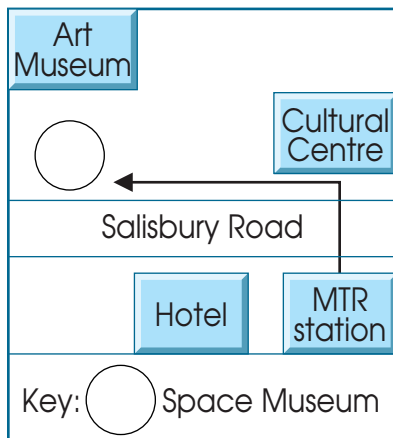

turn left    walk straight on    get out of  
in front of    cross the road

To get to the Space Museum, (1) \_\_\_\_\_  
\_\_\_\_\_ the MTR station Exit L6. Then  
(2) \_\_\_\_\_ to the Cultural  
Centre and (3) \_\_\_\_\_.  
(4) \_\_\_\_\_ Salisbury  
Road. You will see the Space Museum (5) \_\_\_\_\_  
\_\_\_\_\_ of the Art Museum.

**E** Harry is now in the Space Museum. He is looking at a display board. Fill in the blanks with the correct forms of words in the brackets. (16 marks)

 Suggested time: 4 minutes



In the olden times, people (1) \_\_\_\_\_ (not know) much about space. They (2) \_\_\_\_\_ (think) the Earth (3) \_\_\_\_\_ (be) flat. Later, they (4) \_\_\_\_\_ (begin) to find out more about space. People even (5) \_\_\_\_\_ (start) to send humans into space too. Two Americans (6) \_\_\_\_\_ (land) on the moon in 1969. They (7) \_\_\_\_\_ (be) the first humans to land on the moon. They (8) \_\_\_\_\_ (take) some moon rocks there back to the Earth.





**F** Harry is writing in his diary about the visit. Complete his diary entry using 'so' or 'because'. (8 marks)  Suggested time: 3 minutes

 24 March Saturday

Cloudy

 Today, our class went to the Space Museum. We first listened to a talk about space. The guide was very interesting (1) \_\_\_\_\_  
 we enjoyed it very much. During free time, I wanted to know more about space (2) \_\_\_\_\_ I looked at the display boards about people travelling into space. It was amazing! We left at 12:30 p.m. I fell asleep on the way back (3) \_\_\_\_\_ I was so tired.

 I will visit the Space Museum again next Saturday (4) \_\_\_\_\_ there will be a new film about Mars. I will invite James to go with me.  



## Writing (20 marks)

**G** Alice wrote on her blog about her amazing day. Read the blog and write about your amazing day too. Write about 60 words.  Suggested time: 10 minutes

### Alice's blog

6 APRIL

#### An amazing day

Last Sunday, I went to Ocean Park with my family. We went there by bus. We first went to see the pandas. They were very lovely so I took many pictures of them. Then, my brother and I went to take rides. It was very exciting. At night, we had a buffet dinner in a restaurant.



Name: Alice

- Writing hints:**
- Where did you go?
  - Who did you go with?
  - How did you get there?
  - What did you do?

#### An amazing day



---

---

---

---

---

---

---

---

---

---